

Scilab Manual for
Electronic Devices And Circuits
by Prof Mahesh M
Electronics Engineering
Sreenidhi Institute Of Science & Technology¹

Solutions provided by
Prof Mahesh M
Electronics Engineering
Sreenidhi Institute Of Science & Technology

April 2, 2026

¹Funded by a grant from the National Mission on Education through ICT, <http://spoken-tutorial.org/NMEICT-Intro>. This Scilab Manual and Scilab codes written in it can be downloaded from the "Migrated Labs" section at the website <http://scilab.in>

Contents

List of Scilab Solutions	4
1 Determine the base,emitter,collector current of Common Base config ,given alpha value	6
2 Determine operating point of Fixed Bias circuit ,given transistor gain,base to emitter voltage	8
3 Determine ouput voltage of circuit given V_{be} for transistors Q1,Q2	10
4 Determine value of drain current I_d and gate source voltage V_{gs} for self bias circuit	12
5 Find Freq of RC phase shift oscillator if the 3 resistances are equal and 3 capacitances are equal	14
6 Given N-channel JFET determine the value of R_s to achieve self bias condition	16
7 Find the capacitance value in Wien-bridge oscillator given value of R and Freq of oscillation	18
8 Design Zener Shunt voltage regulator with given specifications	20
9 Determine input,output impedance voltage and current gain given h-parameters of transistor	22

10 Design Schmitt Trigger circuit using 2 silicon NPN transistors with given configuration

24

List of Experiments

Solution 1.1	1	6
Solution 2.2	2	8
Solution 3.3	3	10
Solution 4.4	4	12
Solution 5.5	5	14
Solution 6.6	6	16
Solution 7.7	7	18
Solution 8.8	8	20
Solution 9.9	9	22
Solution 10.10	10	24
AP 1	Fig6	28
AP 2	Fig5	29
AP 3	Fig4	30
AP 4	Fig3	31
AP 5	Fig2	31
AP 6	Fig1	32

List of Figures

Experiment: 1

Determine the
base,emitter,collector current
of Common Base config ,given
alpha value

check Appendix [AP 6](#) for dependency:

EX1.jpg

Scilab code Solution 1.1 1

```
1 //Determine the base ,emitter ,collector current of  
   Common base config  
2 //Windows 10  
3 //Scilab 6.0.0  
4  
5 clc;  
6 clear;  
7 close;  
8  
9 alpha=0.95 //in Ampere  
10 R1=5*10e3 //in kilo ohms
```

```
11 Vd=4.5          //in volts
12 Ic=Vd/R1        //Current flowing through resistor (or)
    Collector Current in milli Ampere
13 Ie=Ic/alpha     //emitter current in milli Ampere
14 Ib=Ie-Ic        //base current in micro Ampere
15 Ic1=Ic*10e3
16 Ib1=Ib*10e6
17 Ie1=Ie*10e3
18 mprintf('The value of Ib is %.1fuA ',Ib1)
19 mprintf('\nThe value of Ic is %.1fmA ',Ic1)
20 mprintf('\nThe value of Ie is %.3fmA ',Ie1)
```

Experiment: 2

Determine operating point of Fixed Bias circuit ,given transistor gain,base to emitter voltage

check Appendix [AP 5](#) for dependency:

EX2.jpg

Scilab code Solution 2.2 2

```
1 //Determine the operating point of Fixed Bias ckt
   given transistor gain ,Vbe
2 //Windows 10
3 //Scilab 6.0.0
4
5 clc;
6 clear;
7 close;
8
9 tgain=100           //beta (or) transistor gain //
   unitless
```

```

10 Vcc=15 //in volts
11 Vbe=0.7 //base emitter voltage in volts
12 Rb=1*10e6 //resistance in ohms
13 Rc=4*10e3 //resistance in ohms
14 Ic=Vcc/Rc
15 Icq=tbgain*((Vcc-Vbe)/Rb) //collector current in
    milli Ampere
16 Vceq=Vcc-(Icq*Rc) //collector emitter voltage in
    volts
17 Vce=Vcc-(Ic*Rc) //load line equation
    for fixed-bias ckt
18 //Substituting Ic=0,Vce=Vcc=15v
19 Ic1x=0
20 Vcex=Vcc-(Ic1x*Rc)
21 //coordinates of load line on x-axis are(0 mA,15V)
22 //Substituting Vce=0,Ic=Vcc/Rc=3.75mA
23 Vcey=0
24 Icy=Vcc/Rc
25 //coordinates of load line on y-axis are(3.75 mA,0V)
26 Icq=Icq*10e3
27 Vce=Vce*10e3
28 Icy=Icy*10e3
29 mprintf('Collector Current Icq=%0.2fmA',Icq)
30 mprintf('\nCollector-Emmitter Voltage Vceq=%0.2fV',
    Vceq)
31 mprintf('\nX-Axis Coordinates(%dmA,%dV)',Ic1x,Vcex)
32 mprintf('\nY-Axis Coordinates(%0.2fmA,%dV)',Icy,Vcey)
33 mprintf('\nOperating Point is Icq=%0.2fmA and Vceq=%0
    .2fV',Icq,Vceq)
34
35 //plotting the load line
36 x=[Ic1x,Vcex]
37 y=[Icy,Vcey]
38 clf()
39 plot(x,y)
40 xtitle('Load Line');
41 xlabel('Vce(V)');ylabel('Ic (mA)');

```

Experiment: 3

Determine output voltage of circuit given V_{be} for transistors Q1,Q2

check Appendix [AP 4](#) for dependency:

EX3.jpg

Scilab code Solution 3.3 3

```
1 //Determine output voltage of a ckt
2 //Windows 10
3 //Scilab 6.0.0
4
5 clc;
6 clear;
7 close;
8
9 Vcc=15           //in volts
10 Vbe2=0.7       //in volts
11 Vq1=1.7        //in volts
12 Rb1=1*10^3     //in kilo ohms
13 Rb2=100        //in ohms
```

```
14 Ie1=(Vq1-Vbe2)/Rb2
15 Ic1=Ie1
16 Vc1=Vcc-(Rb1*Ie1)
17 Q2=Vc1
18 Vb2=Vc1
19 Ve2=Vb2-Vbe2
20 Vout=Ve2
21 Ie1=Ie1*10^3 //in milli Ampere
22 mprintf('Ie1:%d mA',Ie1)
23 mprintf('\nVc1:%d V',Vc1)
24 mprintf('\nQ2:%d V',Q2)
25 mprintf('\nVe2:%.1f V',Ve2)
26 mprintf('\nVout:%.1f V',Vout)
```

Experiment: 4

Determine value of drain current I_d and gate source voltage V_{gs} for self bias circuit

check Appendix [AP 3](#) for dependency:

EX4.jpg

Scilab code Solution 4.4 4

```
1 //Determine value of drain current- $I_d$  and gate-  
   source voltage- $V_{gs}$  for self-bias ckt  
2 //Windows 10  
3 //Scilab 6.0.0  
4  
5 clc;  
6 clear;  
7 close;  
8  
9 Vdd=20           //in Volts  
10 Vds=15          //in Volts  
11 Rd=4*10^3       //in ohms  
12 Rs=0.4*10^3    //in ohms
```

```
13 Id=(Vdd-Vds)/(Rd+Rs)           //in milli Ampere
14 Vgs=Id*Rs                       //in Volts
15 Id=Id*10^3
16 mprintf('Drain Current Id is %.2fmA',Id)
17 mprintf('\nGate-Source Voltage Vgs is %.3fV',Vgs)
```

Experiment: 5

Find Freq of RC phase shift oscillator if the 3 resistances are equal and 3 capacitances are equal

Scilab code Solution 5.5 5

```
1 //Given N-channel JFET determine the value of rs to
   achieve Self Bias condition
2 //Windows 10
3 //Scilab 6.0.0
4
5 clc;
6 clear;
7 close;
8
9 Idss=40*10^-3           //in milli Ampere
10 Vp=-10                 //in Volts
11 Vgs=-5                 //in Volts
12 Vds=5                  //in Volts
13 Id=Idss*((1-(Vgs/Vp))^2)
14 Rs=Vds/Id
```

```
15 Id=Id*10^3 //in milli Ampere
16 mprintf('Id is %dmA',Id)
17 mprintf('\nRs is %d ohms',Rs)
```

Experiment: 6

**Given N-channel JFET
determine the value of R_s to
achieve self bias condition**

Scilab code Solution 6.6 6

```
1 //Find freq. of RC phase shift oscillator
2 //Windows 10
3 //Scilab 6.0.0
4
5 clc;
6 clear;
7 close;
8
9 R1=200*10^3           //resistance 1 in kilo ohms
10 R2=200*10^3          //resistance 2 in kilo ohms
11 R3=200*10^3          //resistance 3 in kilo ohms
12 C1=100*10^-12        //capacitance 1 in pico
    farads
13 C2=100*10^-12        //capacitance 2 in pico farads
14 C3=100*10^-12        //capacitance 3 in pico farads
15 fr=1/(2*%pi*R1*C1*sqrt(6))
16 fr=fr*10^-3          //in kilo Hertz
```

```
17 mprintf('The frequency of RC phase shift oscillator  
is %f Hz',fr)
```

Experiment: 7

Find the capacitance value in Wien-bridge oscillator given value of R and Freq of oscillation

Scilab code Solution 7.7 7

```
1 //Find the capacitance value in Wien-bridge
   oscillator
2 //Windows 10
3 //Scilab 6.0.0
4
5 clc;
6 clear;
7 close;
8
9 R=100*10^3           //resistance in kilo ohms
10 fr=10*10^3          //frequency of oscillation in kilo
   hertz
11 C=1/(2*%pi*R*fr)
12 C=C*10^12           //in pico Farad
13 mprintf('The capacitance value in the Wien-bridge
```

oscillator is: %.2f pF',C)

Experiment: 8

Design Zener Shunt voltage regulator with given specifications

Scilab code Solution 8.8 8

```
1 //Design Zener Shunt-Voltage regulator
2 //Windows 10
3 //Scilab 6.0.0
4
5 clc;
6 clear;
7 close;
8
9 Vo=10 //in volts
10 Vinmin=20 //lowercase Vin in volts
11 Vinmax=30 //uppercase Vin in volts
12 Ilmin=30*10^-3 //lowercase Il in volts
13 Ilmax=50*10^-3 //uppercase Il in volts
14 Izmin=20*10^-3 //lowercase Iz in milli
    Ampere
15 Izmax=40*10^-3 //uppercase Iz in milli
    Ampere
```

```
16 Vz=Vo
17 Pz=Vz*Izmax
18 mprintf( 'Pz:%.2f W',Pz)
19 //Pz=0.4W,Hence a 0.5Z 10 zener can be selected
20 Rlmin=(Vo/Ilmax)
21 Rlmax=(Vo/Ilmin)
22 Rmax=((Vinmax-Vo)/(Ilmin+Izmax))
23 Rmin=((Vinmin-Vo)/(Ilmax+Izmin))
24 R=(Rmax+Rmin)/2
25 mprintf( '\nRlmin:%d ohms ',Rlmin)
26 mprintf( '\nRlmax:%d ohms ',Rlmax)
27 mprintf( '\nRmax:%d ohms ',Rmax)
28 mprintf( '\nRmin:%d ohms ',Rmin)
29 mprintf( '\nR:%d ohms ',R)
```

Experiment: 9

Determine input,output impedance voltage and current gain given h-parameters of transistor

check Appendix [AP 2](#) for dependency:

EX9.jpg

Scilab code Solution 9.9 9

```
1 //Determine input&output impedance voltage and
   current gain given h-parameters of transistor
2 //Windows 10
3 //Scilab 6.0.0
4
5 clc;
6 clear;
7 close;
8
9  $I_c=3*10^{-3}$  //collector current in milli
   Ampere
```

```

10 hfe=60 //beta value
11 Vcc=12 //in Volts
12 Vbe=0.6 //base emitter voltage in
    Volts
13 Rc=5.1*10^3 //resistance in kilo ohms
14 Rb=220*10^3 //resistance in kilo ohms
15 hie=500 //in ohms
16 Zi=hie
17 Zo=Rc
18 Av=(-hfe*Rc)/hie
19 mprintf('Av:%d',Av)
20 Al=-hfe
21 mprintf('\nAl:%d',Al)
22 //from re model
23 Ib=(Vcc-Vbe)/Rb
24 Ib1=Ib*10^6 //in micro Ampere
25 mprintf('\nIb:%.1 f uA',Ib1)
26 Ie=hfe*Ib
27 Ie1=Ie*10^3 //in milli Ampere
28 mprintf('\nIe:%.3 f mA',Ie1)
29 re=(26*10^-3)/Ie
30 mprintf('\nre:%.2 f ohms',re)
31 Zi=hfe*re
32 mprintf('\nZi:%.1 f ohms',Zi)
33 Zo=Rc
34 Zo=Zo*10^-3
35 mprintf('\nZo:%.1 f k ohms',Zo)
36 Av=-Rc/re
37 mprintf('\nAv:%d',Av)
38 Al=-hfe
39 mprintf('\nAl:%d',Al)

```

Experiment: 10

Design Schmitt Trigger circuit using 2 silicon NPN transistors with given configuration

check Appendix [AP 1](#) for dependency:

EX10.jpg

Scilab code Solution 10.10 10

```
1 //Design schmitt trigger ckt using 2 silicon npn
   transistors with given config
2 //Windows 10
3 //Scilab 6.0.0
4
5 clc;
6 clear;
7 close;
8
9 UTP=5           //in volts
10 Vb2=5          //in volts
11 Vbe=0.7        //in volts
12 Vcc=12         //in volts
```

```

13 LTP=3 //in volts
14 Ic=2*10^-3 //in milli Amperes
15 Ic2=2*10^-3 //in milli Amperes
16 hfemin=100
17 UTP=Vb2
18 Ve=Vb2-Vbe
19 mprintf( '\nVe: %.2 f V', Ve)
20 Ie=Ic
21 Ie=Ie*10^3
22 mprintf( '\nIe: %d mA', Ie)
23 Re=Ve/Ie
24 mprintf( '\nRe: %.2 f k ohms', Re)
25 //taking q2 saturated
26 Vcesat=0.2 //in volts
27 IcRc2=Vcc-Ve-Vcesat
28 mprintf( '\nIcRc2: %.1 f V', IcRc2)
29 Rc2=(Vcc-Ve-Vcesat)/Ic
30 Rc2=Rc2*10^-3
31 mprintf( '\nRc2: %.2 f k ohms', Rc2)
32 I2=0.1*Ic2
33 I2=I2*10^3
34 mprintf( '\nI2: %.2 f mA', I2)
35 R2=Vb2/I2
36 mprintf( '\nR2: %d k ohms', R2)
37 Ib2=Ic2/hfemin
38 Ib2=Ib2*10^6
39 mprintf( '\nIb2: %d uA', Ib2)
40 I1=I2+Ib2
41 //substituting the values and equating I1
42 //(Vcc-Vb2)/(Rc1+R1)=I1=0.2*10^-3+20*10^-6
43 //I2-5/(Rc1+R1)=0.22*10^-3
44 Rc1r1=(Vcc-Vb2)/I1
45 //Rc1+R1=7/(0.22*10^-3)
46 //when q1 is on Vi=LTP=Vb2=3v
47 Vi=LTP
48 Vb1=3
49 Vb2=3
50 I1=Vb2/R2

```

```
51 // I1=I1*10^3
52 fprintf( '\nI1: %.2 f mA', I1)
53 Ie=(Vb1-Vbe)/Re
54 Ic1=Ie
55 fprintf( '\nIc1: %.2 f mA', Ic1)
56 fprintf( '\nIe: %.2 f mA', Ie)
57
58 // Vcc=Rc1(Ic1+I1)+I1(R1+R2)
59 Rc1=(Vcc-I1*(Rc1r1+R2))/(Ie)
60 Rc1=Rc1*10^-3
61 R1=Rc1r1-Rc1
62 //Rb<hfeRe
63 Rb=(hfemin*Re)/10
64 fprintf( '\nRb: %.2 f k ohms', Rb)
```

Appendix

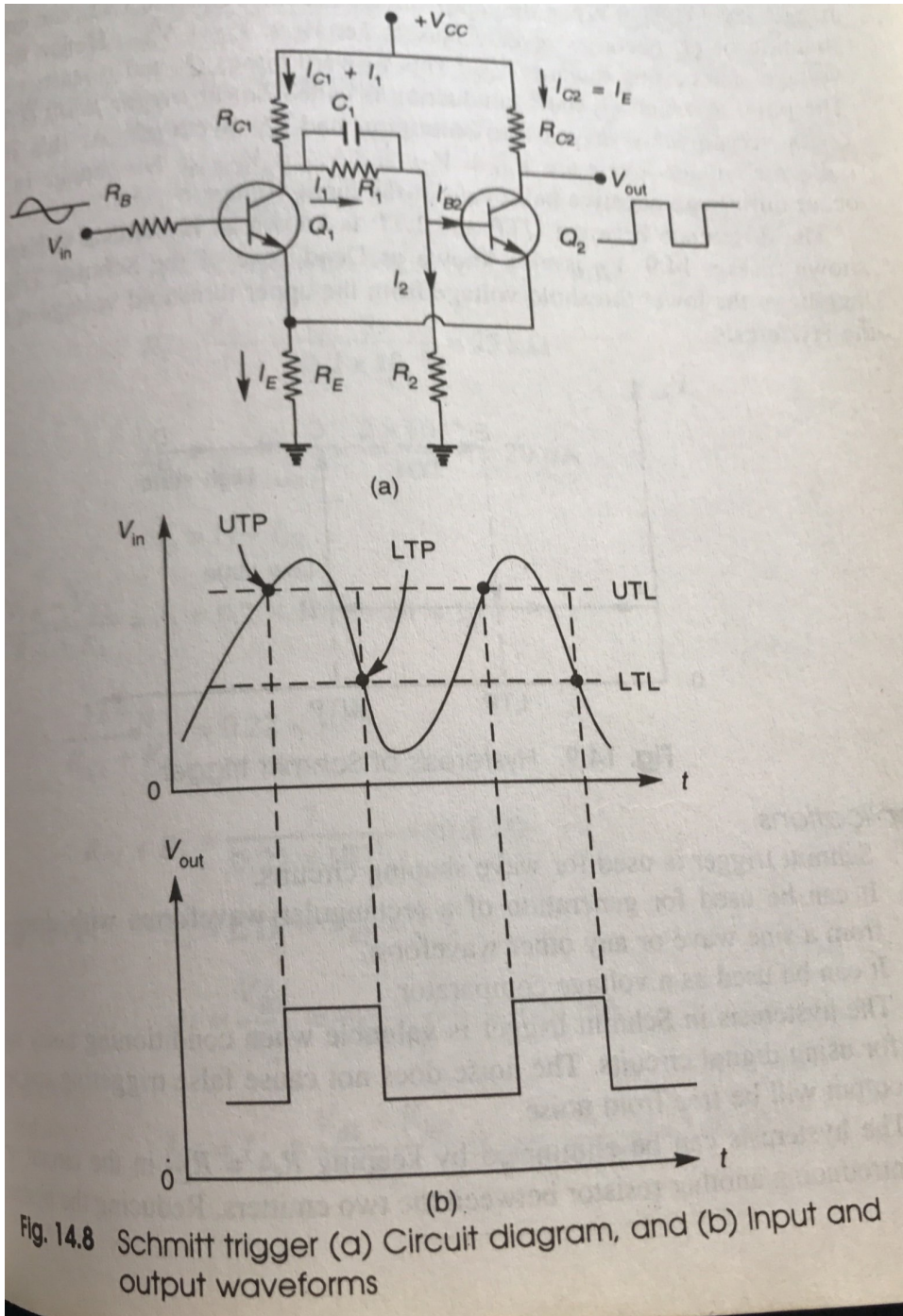

Fig6

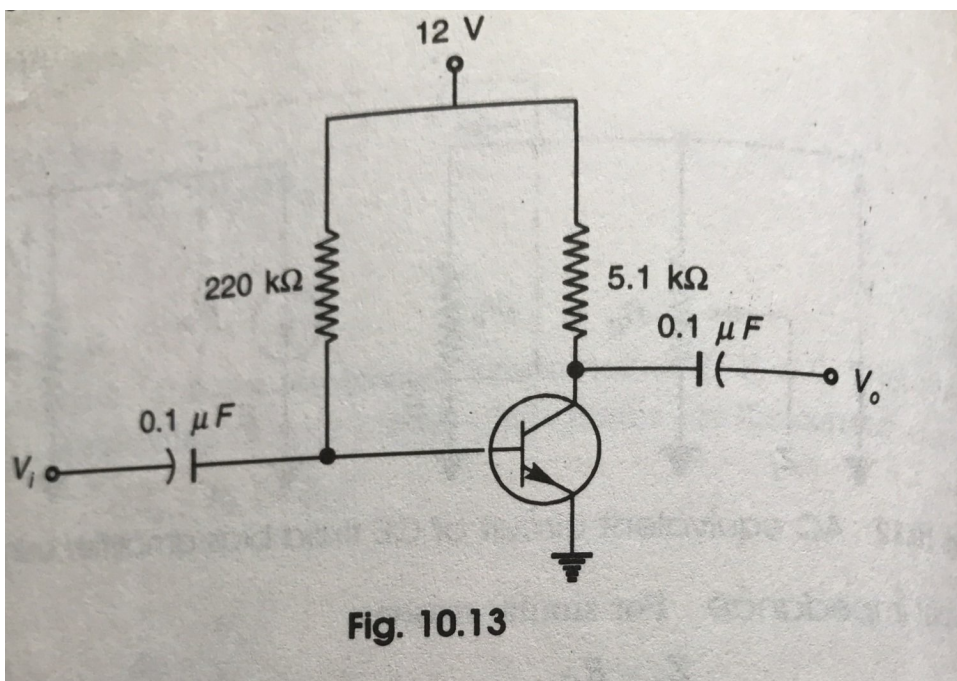

Fig. 10.13

Fig5

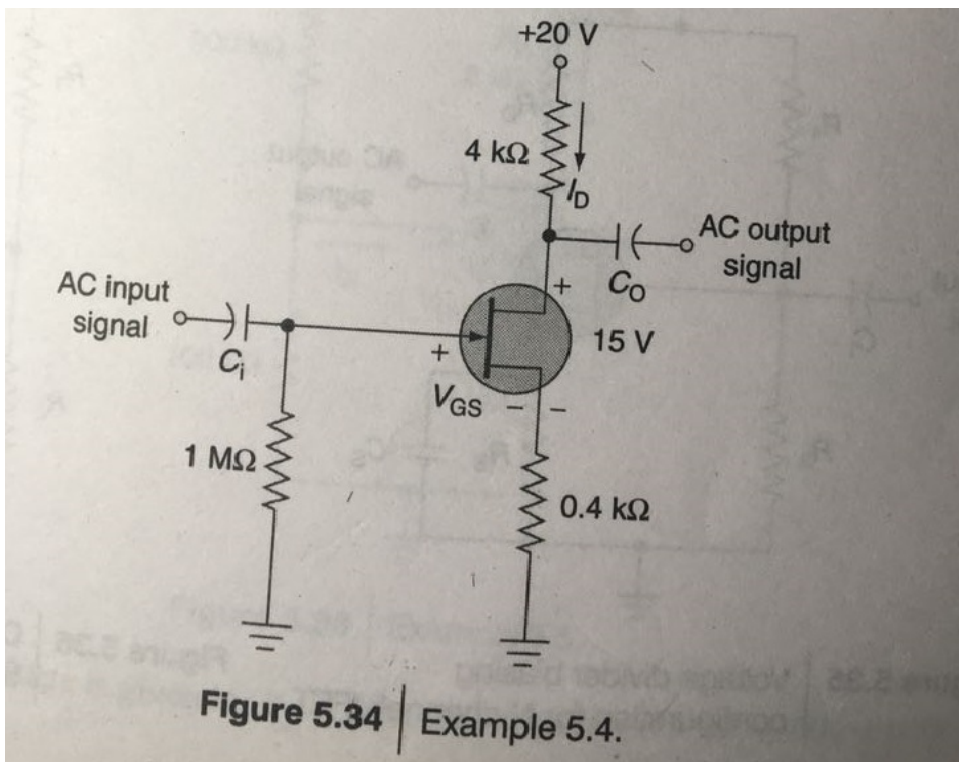

Figure 5.34 | Example 5.4.

Fig4

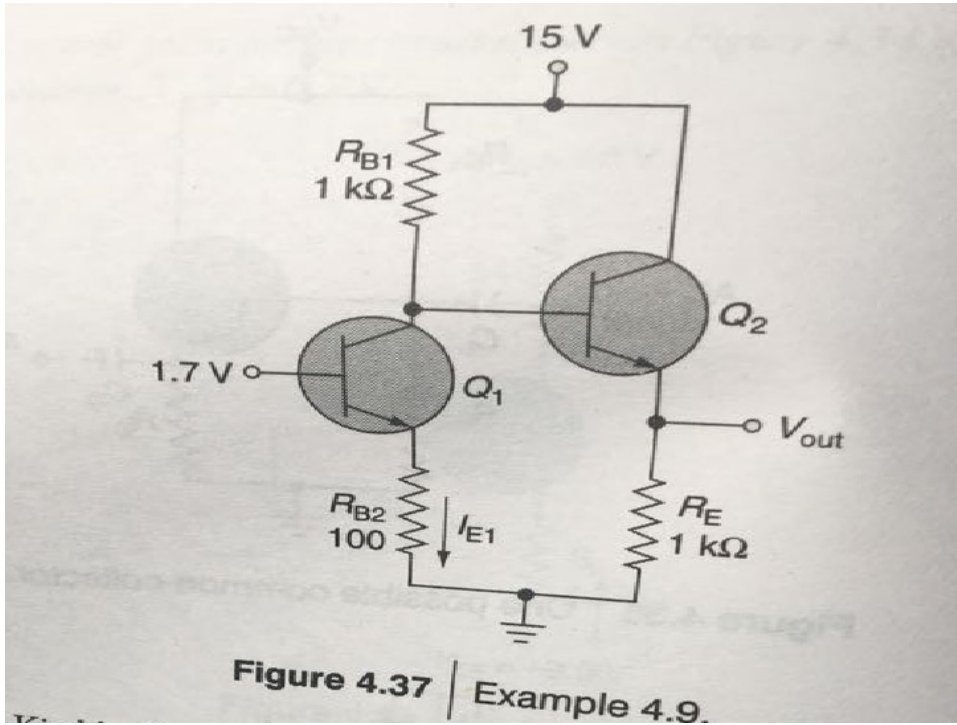

Fig3

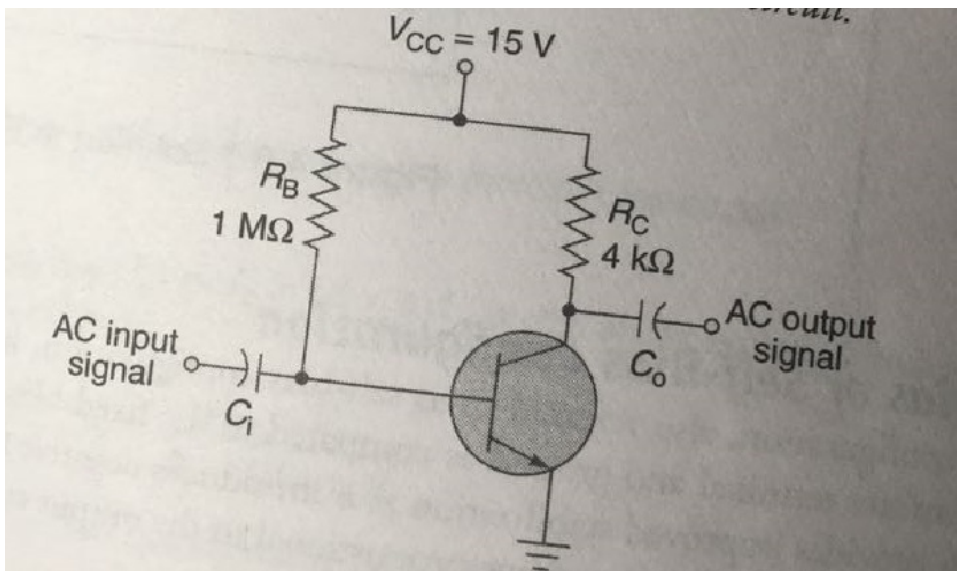

Fig2

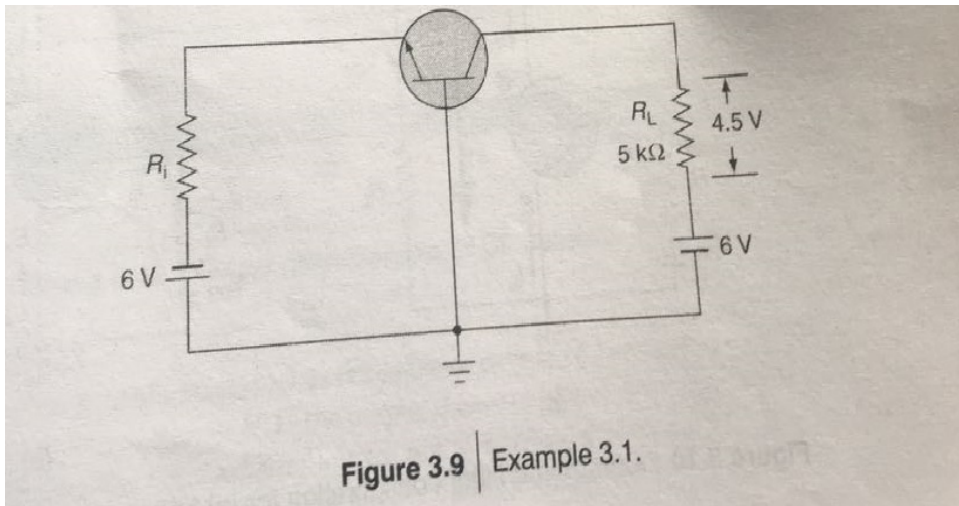

Fig1