

Scilab Manual for
Simulation Lab
by Dr Santosh Desai
Instrumentation Engineering
BMS College of Engineering, Bangalore¹

Solutions provided by
Dr Santosh Desai
Instrumentation Engineering
Bmsce

June 19, 2026

¹Funded by a grant from the National Mission on Education through ICT, <http://spoken-tutorial.org/NMEICT-Intro>. This Scilab Manual and Scilab codes written in it can be downloaded from the "Migrated Labs" section at the website <http://scilab.in>

Contents

List of Scilab Solutions	3
1 Transient response of first order system - using programming	5
2 Transient response of second order system - using programming	8
3 Transient response of first order system - using Xcos	12
4 Transient response of second order system - using Xcos	14
5 Solution of branch current and voltages for a given circuit by applying KCL & KVL	16

List of Experiments

Solution 1.1	Transient response of first order system using programming	5
Solution 2.2	Transient response of second order system using programming	8
Solution 5.5	Current in a circuit using KVL KCL	16

List of Figures

1.1	Transient response of first order system using programming .	7
2.1	Transient response of second order system using programming	11
3.1	Step Response of RC Circuit using Xcos	13
3.2	Step Response of RC Circuit using Xcos	13
4.1	Step response of second order system using xcos	15
4.2	Step response of second order system using xcos	15
5.1	Current in a circuit using KVL KCL	17
5.2	Current in a circuit using KVL KCL	18

Experiment: 1

Transient response of first order system - using programming

Scilab code Solution 1.1 Transient response of first order system using programming

```
1 //windows OS(10/7/8.1) . Scilab 6.0.1 (64-bit)
2 //toolbox null
3
4 // Transient response of RC Network using output
   equation method
5
6 clc
7 clear
8
9 R=500 // Resistance
   in a network
10 Ei=5 // Amplitude
   of input step signal
11 t=0:0.001:1;
12
13 //Case-1:
14 C1=10e-6 // Capacitance
   value in RC circuit 10uF provided by user
```

```

15 Y1=R*C1
16 E1=Ei*(1-exp(-t/Y1))           // Formula for
    output voltage across capacitor
17 xlabel('Time')                 //Leveling x axis
    as time
18 ylabel('Output voltage(V)')    //Leveling y
    axis as output voltage
19 title('Transient Response of RC circuit at Different
    Capacitance') //Title of Graph
20 plot(t,E1)                     //Output
    Response with respect to time
21 plot(E1,"b")                   //Blue colour at
    C1
22
23 //Case-2:
24 C2=100e-6                       //
    Cacitance value in RC circuit 100uF provided by
    user
25 Y2=R*C2
26 E2=Ei*(1-exp(-t/Y2))          // For output
    voltage across capacitor
27 xlabel('Time(s)')              //Leveling
    x axis as time
28 ylabel('Output voltage(V)')    //Leveling y
    axis as output voltage
29 plot(t,E2)
30 plot(E2,"g")                   //Green colour at C2
31
32 //Cse-3:
33 C3=200e-6                       // Cacitance value in
    RC circuit 200uF provided by user
34 Y3=R*C3
35 E3=Ei*(1-exp(-t/Y3))          // For output
    voltage across capacitor
36 xlabel('Time(s)')              //Leveling x
    axis as time
37 ylabel('Output voltage(V)')    //Leveling y
    axis as output voltage

```

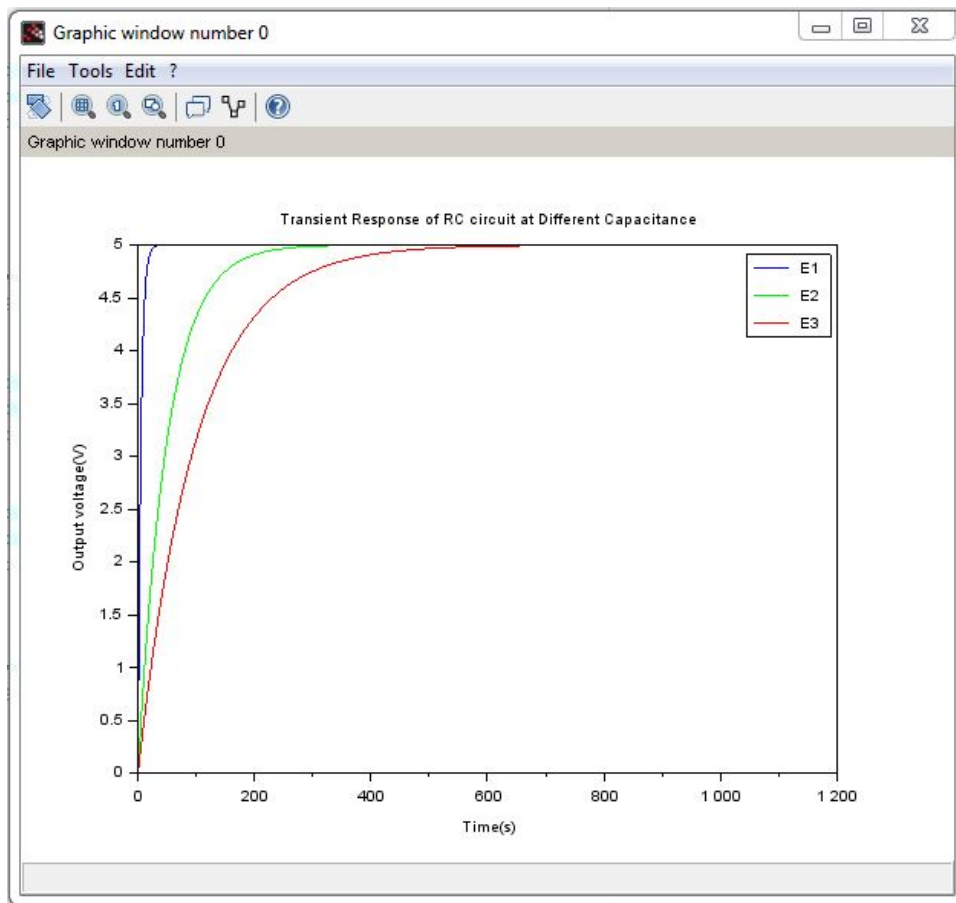

Figure 1.1: Transient response of first order system using programming

```

38 plot(t, E3)
39 plot(E3, "r") //Red
    colour at C3
40
41 legends(['E1'; 'E2'; 'E3'], [2, 3, 5], opt=1) //Legend
42 xgrid(1) //Grid

```

Experiment: 2

Transient response of second order system - using programming

Scilab code Solution 2.2 Transient response of second order system using programming

```
1 //windows 10 . Scilab 6.0.1 (64-bit)
2 //toolbox null
3
4 //Transient response of second order system example
   RLC circuit
5 //zeta is damping ratio given by user
6 //If  $0 < \zeta < 1$ , Damped System
7 //If  $\zeta = 1$ , Critically Damped System
8 //If  $\zeta > 1$ , Over Damped System
9 //If  $\zeta = 0$ , Undamped System
10 //wn is the system's natural frequency provided by
   user
11
12
13 clc
14 clear
```

```

15 t=0:0.002:1
16 wn=100;
17
18 xlabel('Time') //Leveling x axis
    as time
19 ylabel('Output voltage(V)') //Leveling y
    axis as output voltage
20 title('Transient Response of Second order System')
    //Title of Graph
21 //for under damped system
22 zeta=0.2
23     phi=acos(zeta);
24     b=sin((wn*sqrt(1-zeta^2)*t)+phi);
25     C=1-(1/sqrt(1-zeta^2))*(exp(-zeta*wn*t).*b)
        //output equation
26     plot(t,C);
27     plot(C,"b") // ouput waveform in
        blue colour
28
29
30 //for over damped system
31 zeta1=5
32     phi1=acos(zeta1);
33     b1=sin((wn*sqrt(1-zeta1^2)*t)+phi1);
34     C1=1-(1/sqrt(1-zeta1^2))*(exp(-zeta1*wn*t).*b1)
35     plot(t,C1);
36     plot(C1,"y") //ouput waveform in
        yellow colour
37
38
39 //for critically damped system
40 zeta2=0.999999
41     phi2=acos(zeta2);
42     b2=sin((wn*sqrt(1-zeta2^2)*t)+phi2);
43     C2=1-(1/sqrt(1-zeta2^2))*(exp(-zeta2*wn*t).*b2)
44     plot(t,C2);
45     plot(C2,"r") //ouput waveform in
        red colour

```

```

46
47
48 //for undamped system
49 zeta3=0
50     phi3=acos(zeta3);
51     b3=sin((wn*sqrt(1-zeta3^2)*t)+phi3);
52     C3=1-(1/sqrt(1-zeta3^2))*(exp(-zeta3*wn*t).*b3)
53     plot(t,C3);
54     plot(C3,"g")           //ouput waveform
        in green colour
55
56
57 legends(['C','C1','C2','C3'],[2,7,5,3],opt=1) //
    Legend
58 //xgrid(1)           //Grid

```

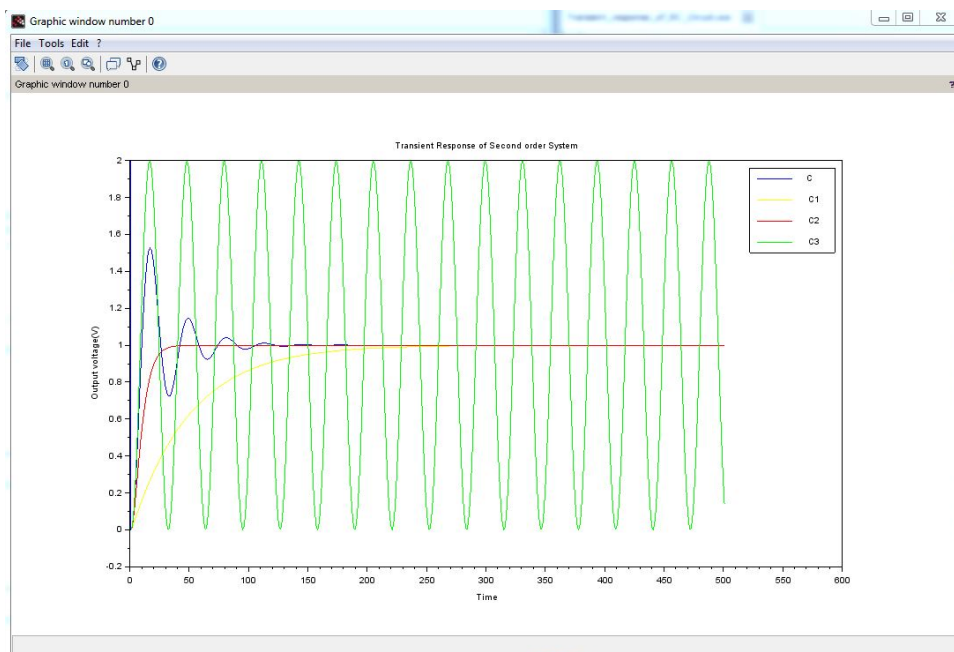

Figure 2.1: Transient response of second order system using programming

Experiment: 3

Transient response of first order system - using Xcos

This code can be downloaded from the website www.scilab.in

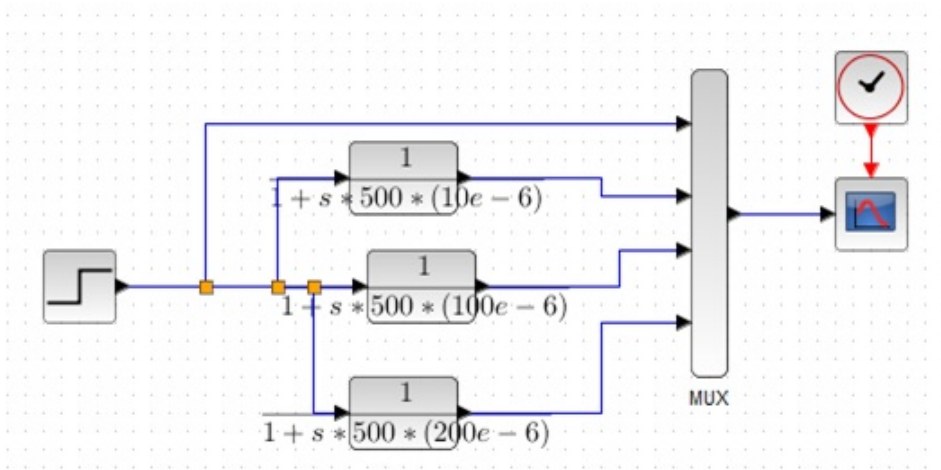

Figure 3.1: Step Response of RC Circuit using Xcos

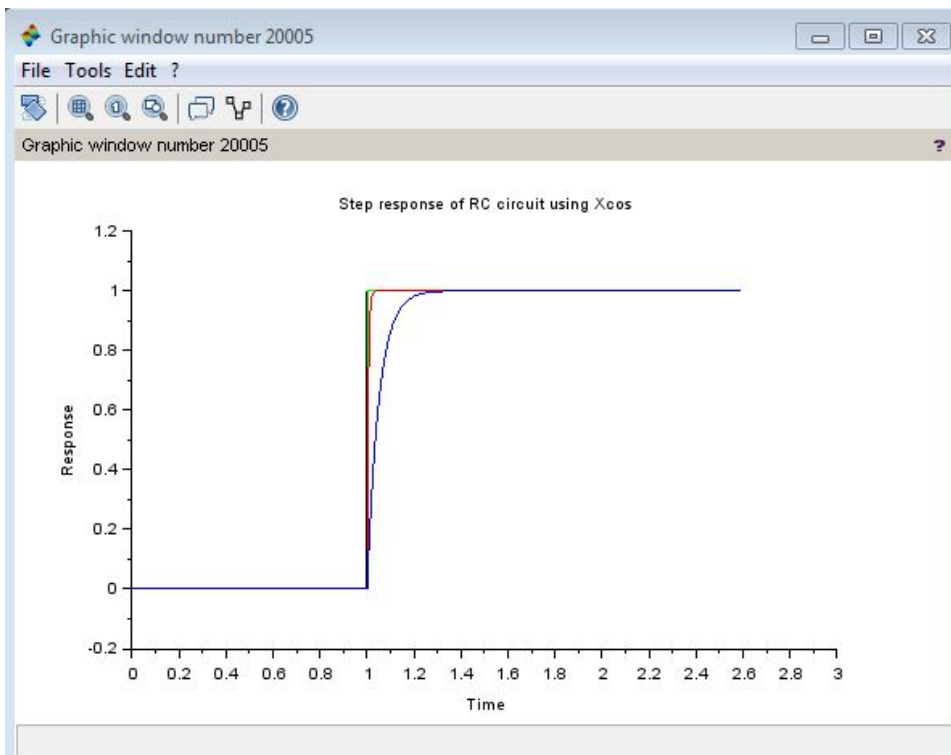

Figure 3.2: Step Response of RC Circuit using Xcos

Experiment: 4

Transient response of second order system - using Xcos

This code can be downloaded from the website www.scilab.in

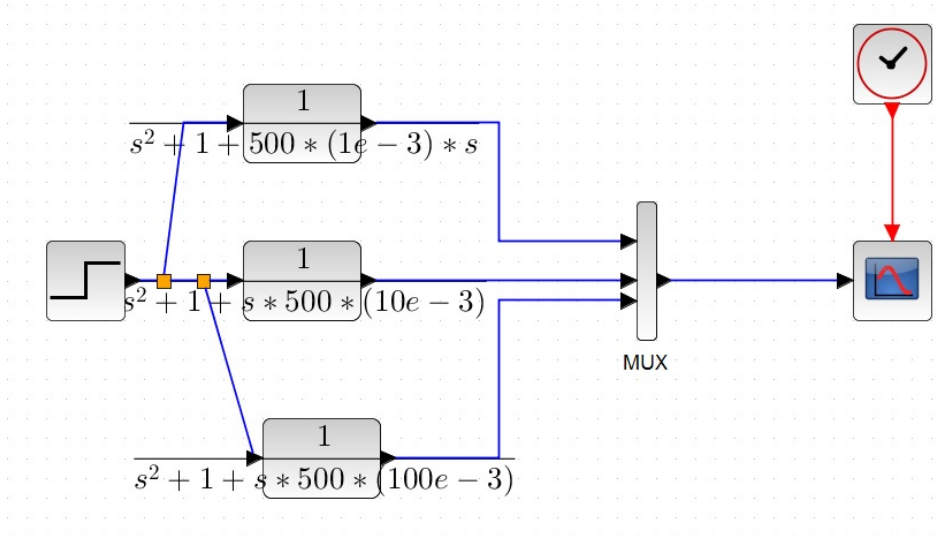

Figure 4.1: Step response of second order system using xcos

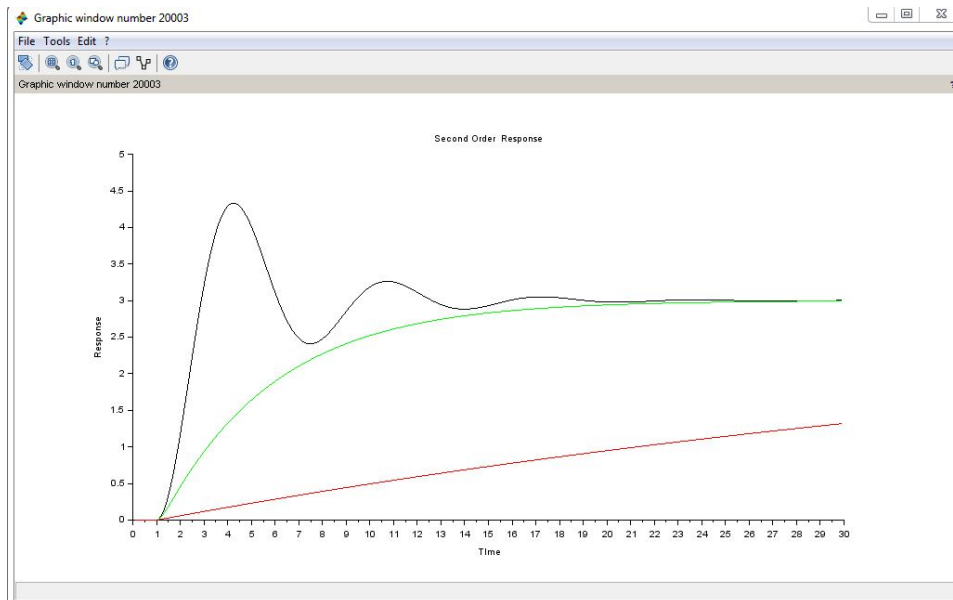

Figure 4.2: Step response of second order system using xcos

Experiment: 5

Solution of branch current and voltages for a given circuit by applying KCL & KVL

Scilab code Solution 5.5 Current in a circuit using KVL KCL

```
1 //windows 10 . Scilab 6.0.1 (64-BIT)
2 //toolbox null
3 // Find current in a circuit using KVL
4 //Current in Wheatstones's bridge using Cramer's
   Rule
5 //The value of V and R is provided by user
6 //V and R written in matrix form
7 //Same direction of current takes positive sign else
   negative
8
9
10 clc
11 clear
```

```
Scilab 6.0.1 Console ? ↶ ✕  
  
I1  
    0.048  
  
I2  
    0.024  
  
I3  
   -0.056  
  
VR1  
   -1.2  
  
VR2  
    2.4  
  
VR3  
    7.2  
  
VR4  
   24.  
  
VR5  
    6.  
  
Voltage across Resistances corresponding to the  
resistance matrix  
-1.2  2.4  7.2  
24.   6.   7.2  
0.   -1.2  24.
```

Figure 5.1: Current in a circuit using KVL KCL

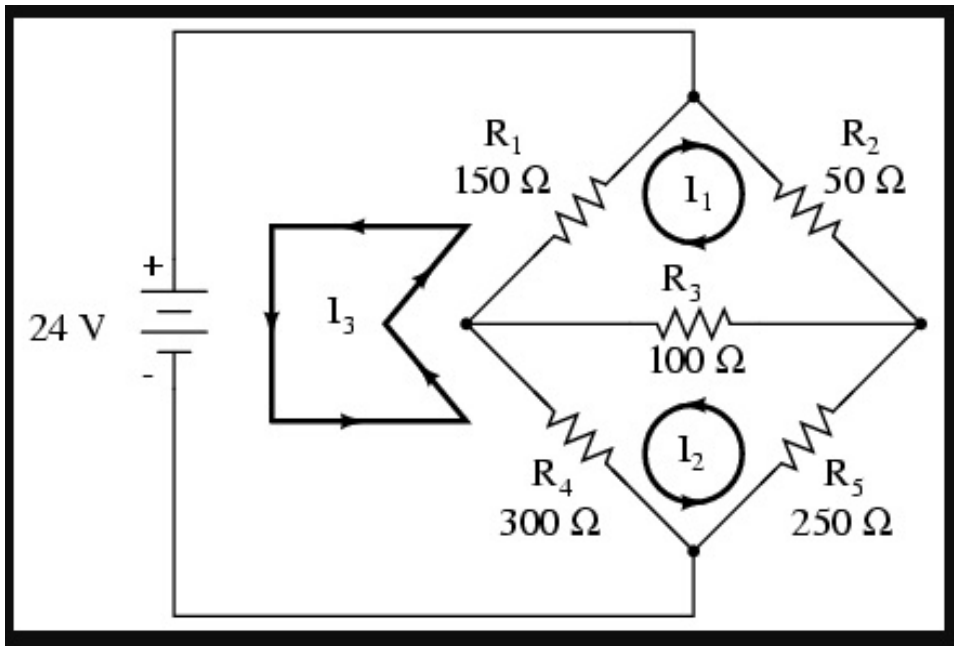

Figure 5.2: Current in a circuit using KVL KCL

```

12 V=[0;0;24]
13 R=[150 50 100;-300 250 100;0 150 -300]
14 I=inv(R)*V;
15 d=det(R);
16 d1=[0 0 24;-300 250 100;0 150 -300];
17 d2=[150 50 100;0 0 24;0 150 -300];
18 d3=[150 50 100;-300 250 100;0 0 24];
19 I1=det(d1)/d //current
    in loop1
20 disp([I1], "I1")
21 I2=det(d2)/d //current in
    loop3
22 disp([I2], "I2")
23 I3=det(d3)/d //current
    in loop3
24 disp([I3], "I3")
25
26 //Calculating Voltage across each resistor

```

```
27 VR1=(I1+I3)*150;
28 disp([VR1], "VR1")
29 VR2=(I1)*50;
30 disp([VR2], "VR2")
31 VR3=(I1+I2)*100;
32 disp([VR3], "VR3")
33 VR4=(I2-I3)*300;
34 disp([VR4], "VR4")
35 VR5=(I2)*250;
36 disp([VR5], "VR5")
37 Vout=[VR1 VR2 VR3;VR4 VR5 VR3;0 VR1 VR4] //
      Voltage across Resistances corresponding to the
      resistance matrix
38 disp([Vout], "Voltage across Resistances
      corresponding to the resistance matrix")
```
